



Experience Innovation

Model: 10" Vacuum-Assisted Solids Handling Pump

Name: 10JSVG

With its heavy-duty cast-iron construction and fast priming capabilities, the Thompson 10JSVG solids handling end suction centrifugal pump leads the industry in construction, industrial and municipal applications. The Thompson 10JSVG is designed for moderate flows up to 4,140 gpm and heads up to 218 feet making it perfect for sewage bypass pumping or general construction dewatering.



Photo shown may not be exact model.
Consult factory for other options.

Pump End Materials	
Pump Casing	Heavy-duty class 30 ductile iron.
Impeller	Dynamically balanced, non-clogging, enclosed, 65-45-12 ductile iron with rear-equalizing vanes to reduce axial loading and prolong seal and bearing life; diameter 14".
Mechanical Seal	Dry-running, grease or oil lubricated with tungsten carbide rotating and silicon carbide stationary seal faces. Single inside mounted, non-pusher type with self-adjusting elastomeric bellows. Other components are 304 stainless steel and Viton.
Head	Rugged, back pull out design, heavy-duty class 30 ductile iron with tapered bore design.
Bearings	Heavy-duty grease lubricated to carry both axial and radial loads.
Bearing Frame	Heavy-duty class 30 ductile iron.
Shaft	SAE1144 high quality stress-proof steel with 416 renewable shaft sleeve.

Technical Specifications

Suction Size	10 in (25.4 cm)	Approximate Dry Weight	8,000 lbs (3,628 kg)
Discharge Size	10 in (25.4 cm)	Best Efficiency	78%
Maximum Solids Handling	3 in (7.62 cm)	Maximum Operating Speed	1,800 rpm
Maximum Operating Temperature	200° F (93.33° C)	Maximum Operating Pressure	94.37 psi (650.66 kPa)

Fuel Tank Options*

	John Deere	Cummins
Modular (M)	127 Gal	32 Hours
Double-Wall (D)	94 Gal	24 Hours
Modular Large Capacity (X)	200 Gal	51 Hours
Double-Wall Large Capacity (Z)	145 Gal	37 Hours

*Contact factory for fuel tank sizes not listed above.

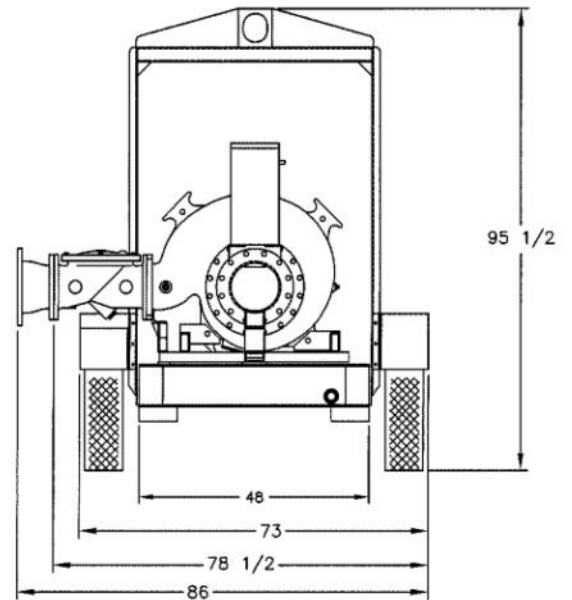
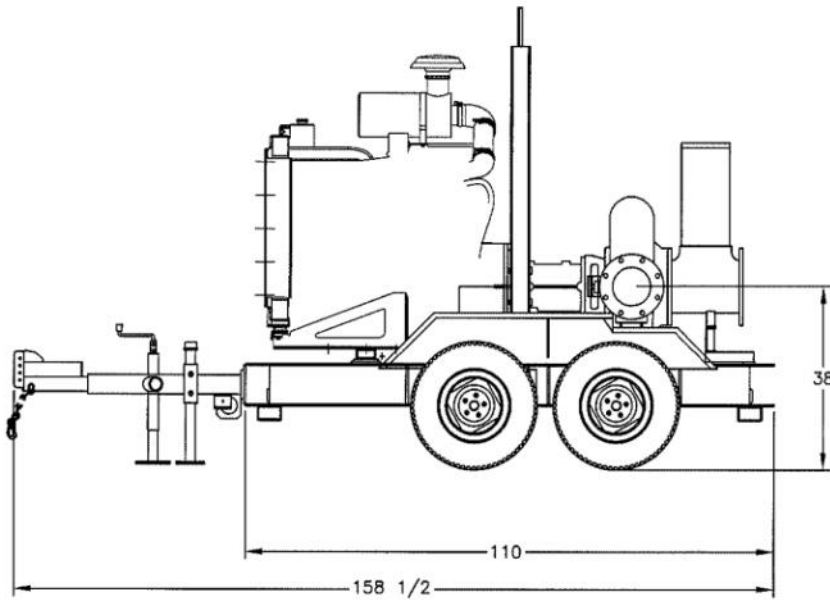
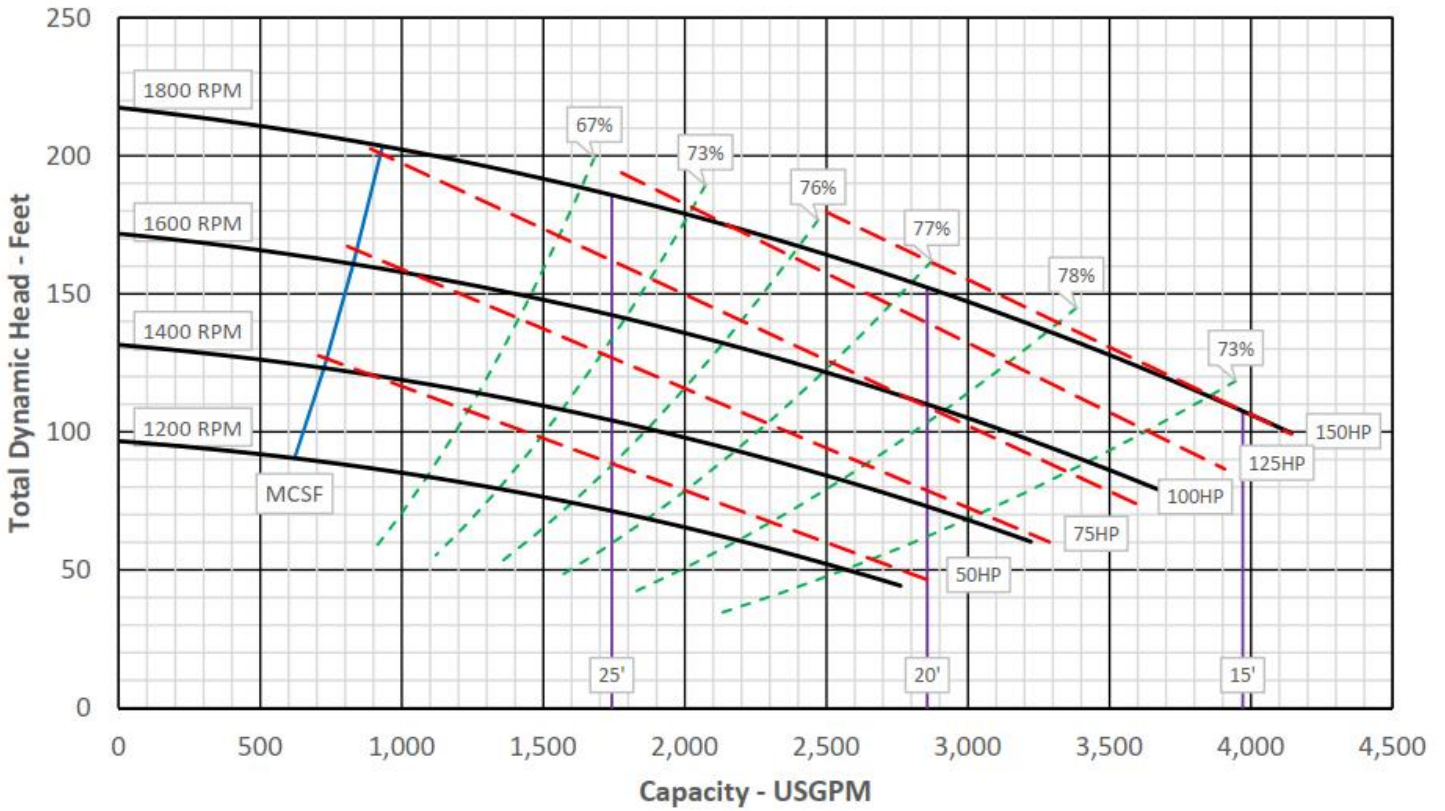

John Deere 45HC06— 139 hp @ 2,200 rpm

Typical Operating Speed	1,800 rpm	Engine Speed	1,800 rpm	Fuel Economy	0.338 lb/hp-hr	Run Time*	17 hrs
Maximum Head	218 ft (66.45 m)	1,800 rpm	0.338 lb/hp-hr	17 hrs			
Maximum Flow Capacity	4,140 gpm (939.8 m ³ /hr)	1,600 rpm	0.333 lb/hp-hr	22 hrs			
Maximum Fuel Consumption	7.47 gph (28.28 L/hr)	1,400 rpm	0.331 lb-hp-hr	32 hrs			

Cummins QSB4.5— 140 hp @ 2,200 rpm

Typical Operating Speed	1,800 rpm	Engine Speed	1,800 rpm	Fuel Economy	0.341 lb/hp-hr	Run Time*	16 hrs
Maximum Head	218 ft (66.45 m)	1,800 rpm	0.341 lb/hp-hr	16 hrs			
Maximum Flow Capacity	4,140 gpm (939.8 m ³ /hr)	1,600 rpm	0.337 lb/hp-hr	22 hrs			
Maximum Fuel Consumption	7.54 gph (28.54 L/hr)	1,400 rpm	0.334 lb-hp-hr	32 hrs			

*Engine run times calculated based on a 127 gallon fuel tank.

Specifications and illustrations are subject to revision without notice and without incurring any obligation for previous or subsequent equipment sold. Thompson Pump (ISO 9001:2015) makes no representation regarding the completeness or accuracy of this information and is not liable for any direct or indirect damages arising from or relating to this information or its use. Capacity & Head are shown for comparative purposes. Consult Thompson factory for exact capabilities.