



8" Hydraulic Submersible Trash Pump 88HST w/78HPU

Thompson hydraulic submersible pumps provide a powerful answer when high heads or high lifts become a factor on job sites. These unique variable speed and variable flow hydraulically driven submersible pumps and power units are manufactured from heavy-duty cast iron and steel for high reliability. The Thompson design allows for maximum versatility in dewatering applications and pumping materials.

Features

- Ability to place pump end in the pumping source
- Eliminates suction lift limitations
- Pumps efficiently at heads up to 240 feet
- Variable speed and flow
- Solids Handling to 3.0"
- 3,300-gpm capacity
- Standard biodegradable lubricants for environmentally sensitive areas

Applications

- Open pit and trench dewatering
- Pipeline dewatering
- Rim ditches
- Manholes
- Sewer lines
- By-pass applications
- Floodwater control
- Drainage and irrigation
- Dewatering of gravel pits, mines, quarries

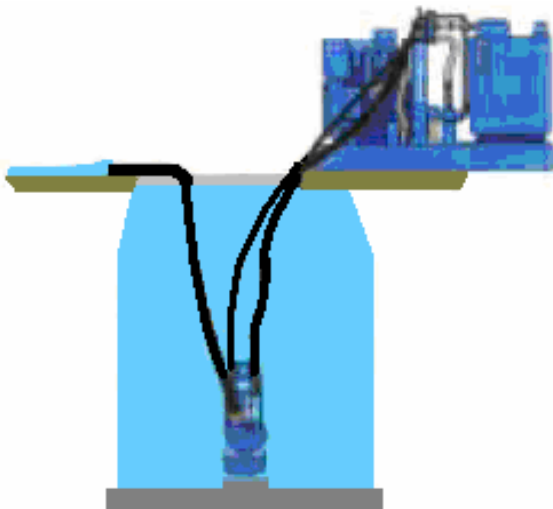

Working Principle

Thompson's hydraulically driven submersible pumps enable the power unit to remain high and dry while the pump head is submerged into the liquid being pumped. Therefore, there is no need to worry about suction lift limitations or priming problems.

These pumps are designed to run dry without damage to the components and are engineered to handle liquids from muddy, trash-laden water to sewage and sludge.

88HST Materials of Construction

Volute: Heavy-duty ASTM A48, class 30 cast iron

Shaft: SAE 1144 Stress Proof Steel, fitted with a renewable 416 stainless steel sleeve

Impeller: Dynamically balanced, non-clogging, enclosed, ductile iron, with rear-equalizing vanes to reduce axial loading and prolong seal and bearing life; diameter 12.5"

Wear Plate: HR1117 Steel

Hydraulic Motor: High efficiency, rotary vane type, 9 cubic inch displacement with SAE D splined output

Hydraulic Couplings: Delivery: 1.25" male Snap-Tite75 series quick disconnect, with dust cap; Return: 1.5" male Snap-Tite 75 series quick disconnect, with dust cap;

Bypass: .75" male Snap-Tite 75 series quick disconnect, with dust cap

Mechanical Seal: Dry running oil lubricated with Tungsten Carbide rotating and stationary seal faces.

Bearings: Heavy-duty, oil lubricated to carry both axial and radial loads

Bearing Housing: Heavy-duty AISI 1040 steel

Strainer: Large, round hole, A36 steel

Discharge Fitting: 8" MNPT and 8" male aluminum cam and groove quick coupler

Seal Protection: Automatic, over-pressure protection system

Oil Cooler: Tubular steel, air to oil



8" Hydraulic Submersible Trash Pump 88HST w/78HPU

88HST Performance Curve

Hydraulic

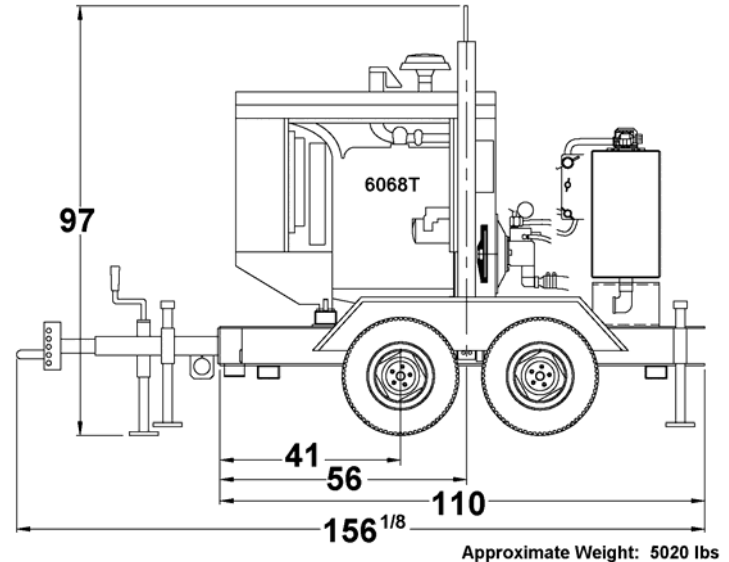
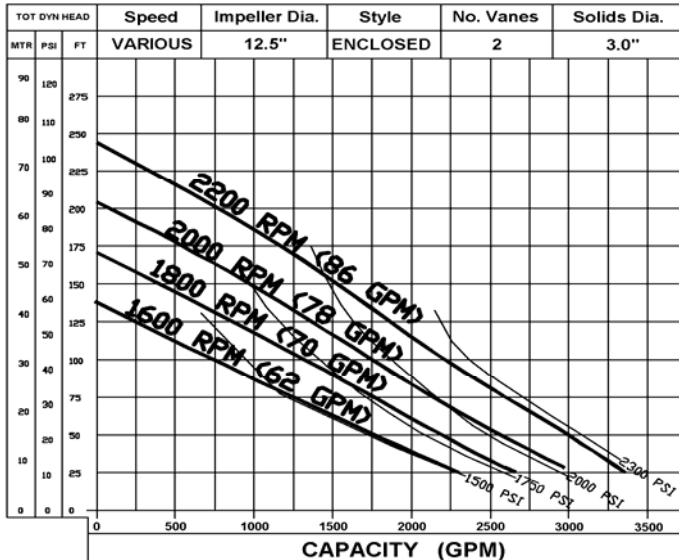

Engine Specifications

Engine: John Deere 6068T, 135 hp @ 2,000 rpm
Type: 6-cylinder, in-line, 4-cycle, water-cooled, turbo charged, direct-injected, Tier II diesel
Standard Equipment: Alternator, radiator, muffler, and exhaust stack with rain protection
Displacement: 414 cubic inches
Fuel Economy: .376 lb/hp-hr @ 1,800 rpm
Safety Shutdowns: High coolant temperature; Low oil pressure

Unit Specifications

Fuel Tank Capacity: 127 US gallons
Fuel Consumption: 6.78 gph
Maximum Operating Speed: 2,000 rpm
Maximum Operating Temperature: 212°F
Maximum Working Pressure: 50 psi
Maximum Casing Pressure: 75 psi

78HPU Materials of Construction

Pump: P365A-2.5, positive displacement, external gear type, single pump, 9 in³ displacement
Control Valve: Needle type
Relief Valve: Pump mounted, internally pilot operated, pressure compensated with vent provision and pressure gauge for system diagnostics
50-gallon Reservoir: Fabricated steel, with internal baffles, large access port, drain valve, sight glass level and temperature gauge, air vent, sump strainer, and shutoff valve
Sump Strainer: 100 mesh spin on type
Return Filter: 100 gpm at 5 psi backpressure, 25 micron, in tank mounted with internal bypass at 25 psi, integral filler/breather
Hydraulic Couplings: Delivery: 1.25" female Snap-Tite 75 series quick disconnect with dust plug; Return: 1.5" female Snap-Tite 75 series quick disconnect, with dust plug; Bypass: .75" female Snap-Tite 75 series quick disconnect, with dust plug
Safety Shutdowns: Low hydraulic fluid level; high hydraulic fluid temperature

In the interest of product improvement, Thompson Pump & Manufacturing reserves the right to change specifications without incurring any obligation for equipment previously or subsequently sold. Capacity, Head and Pump Curve are for comparative purposes. Consult engineering data for exact capabilities.
 4620 City Center Drive, Port Orange, FL, 32129, USA (800) 767-7310 * Fax (386) 761-0362
 Email: sales@thompsonpump.com * www.thompsonpump.com

