

6" Vacuum-Assisted Wellpoint Pump 6VW-DJDST-4045D

Contractors worldwide trust the Thompson vacuum wellpoint pump with its incredible solids handling and high air handling capabilities. Customers experience some of the fastest priming times in the industry with the addition of the *Super Suction* vacuum-assisted priming system. The Thompson 6VW-DJDST-4045D is designed for moderate flows to 1,450 gpm and heads to 88 feet, making it perfect for wellpoint and sock systems or general construction dewatering.

Features

- Standard engine – John Deere 4045D.
- Fully automatic, dry priming to 30 feet
- Moderate heads to 88 feet; Maximum flows to 1,450 gpm
- Handles solids to 3"
- Maximum operating time is 33.5 hours @ 1,800 rpm
- *Super Suction* vacuum-assisted priming system

Super Suction Features & Benefits

- Provides fastest priming system in portable pump dewatering industry
- Prevents discharge of pumping effluent onto the ground
- Eliminates need for a waste hose
- Eliminates need to fill up pump housing with water to obtain original prime at start-up

SUPER SUCTION

VACUUM-ASSISTED PRIMING SYSTEM

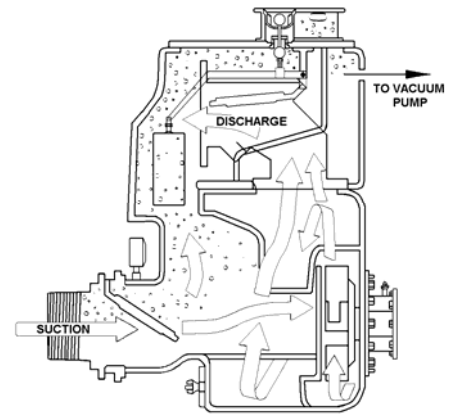

Thompson's exclusive Super Suction vacuum-assisted system works with a self-priming pump to provide the fastest priming in the industry. Water and air passes through a cross section tank and then into the vacuum pump forcing the water to rise in the separation tank until a balance point is reached.

Air cyclone vapor recovery system to prevent discharge of contaminants

Air separator assembly



Discharge priming valve

Cast iron pump with maximum solids capacity of 3"

* Some features not available on all models



6" Vacuum-Assisted Wellpoint Pump 6VW-DJDST-4045D

6VW-DJDST-4045D Dimensions

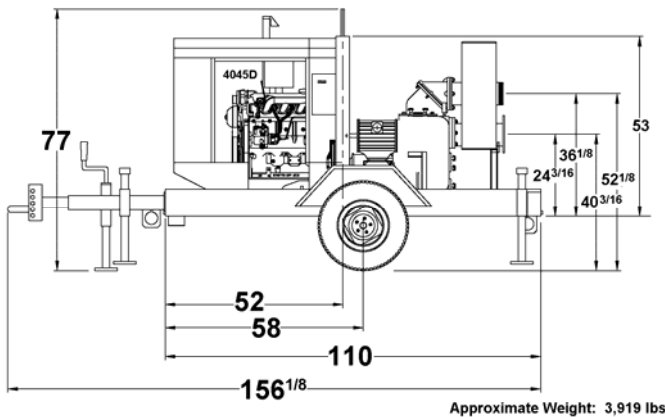

Materials of Construction

Pump Casing: Heavy-duty class 30 cast-iron with built-in volute

Impeller: Dynamically balanced, two-vane, non-clogging, semi-open, ductile iron, with rear-equalizing vanes. Diameter 9.74"

Mechanical Seal: Oil or grease lubricated with Tungsten Carbide rotating and stationary seal faces. Single, inside mounted, non-pusher type with self-adjusting elastomeric bellows.

Head: Rugged, back pull out design, heavy-duty class 30 cast iron with tapered bore design

Bearings and Frame: Heavy-duty grease lubricated to carry both axial and radial loads. Frame is heavy-duty class 30 cast iron.

Shaft: Constructed of high quality carbon steel with a 304 stainless steel shaft sleeve

Wear Plate: Replaceable, class 30 cast iron with abrasion resistant rubber facing to extend service life

6VW-DJDST-4045D Performance Curve

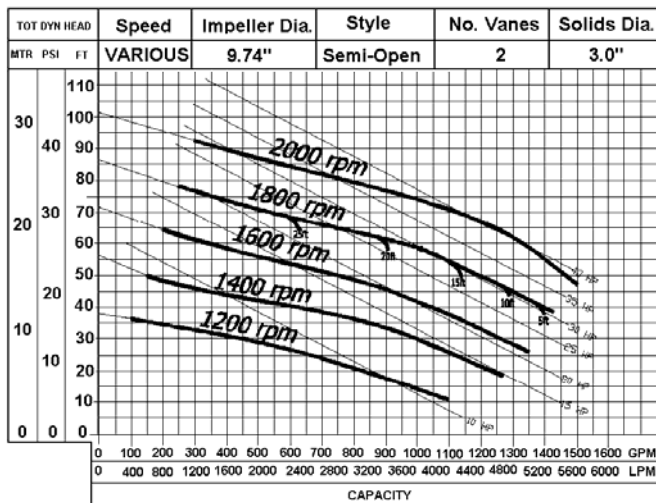

Engine Specifications

Engine: John Deere 4045D, 62 hp @ 1,800 rpm

Type: 4-cylinder, in-line, 4-cycle, water-cooled, natural aspiration, direct-injected, Tier II diesel

Standard Equipment: Alternator, radiator, muffler and exhaust stack with rain protection

Displacement: 276 cubic inches

Fuel Economy: .379 lb/hp-hr @ 1,800 rpm

Safety Shutdowns: High coolant temperature; Low oil pressure

Unit Specifications

Fuel Tank Capacity: 62 US gallons

Fuel Consumption: 1.84 gallons per hour

Maximum Operating Speed: 1,800 rpm

Maximum Operating Temperature: 212°F

Maximum Working Pressure: 56 psi

Maximum Suction Lift: 30 feet

Maximum Casing Pressure: 66 psi

In the interest of product improvement, Thompson Pump & Manufacturing reserves the right to change specifications without incurring any obligation for equipment previously or subsequently sold. Capacity, Head and Pump Curve are for comparative purposes. Consult engineering data for exact capabilities.
4620 City Center Drive, Port Orange, FL, 32129, USA (800) 767-7310 * Fax (386) 761-0362

Email: sales@thompsonpump.com * www.thompsonpump.com

