

6" ENVIOPRIME® Compressor-Assisted Trash Pump 6TSC-DJDST-4045D-MC

With its heavy-duty cast-iron construction, alternate self-priming and wet priming capability, this trash pump works efficiently in construction, industrial and wastewater applications. The Thompson 6TSC-DJDST-4045D-M ENVIOPRIME® Trash Pump is designed for moderate flows and heads to 125 feet and can handle spherical solids to 3" making it perfect for sewage bypass pumping or general construction dewatering.

Features

- Standard engine – John Deere 4045D. Available with a variety of diesel engines.
- Fully automatic, dry priming to 28 feet.
- Moderate heads to 125 feet. Maximum flows to 1,600 gpm.
- Modular frame included with removable drop-on Silent Knight® sound enclosure.
- Maximum operating time is 40 hours @ 1,800 rpm
- ENVIOPRIME® compressor-assisted priming system allows pump to be environmentally safe

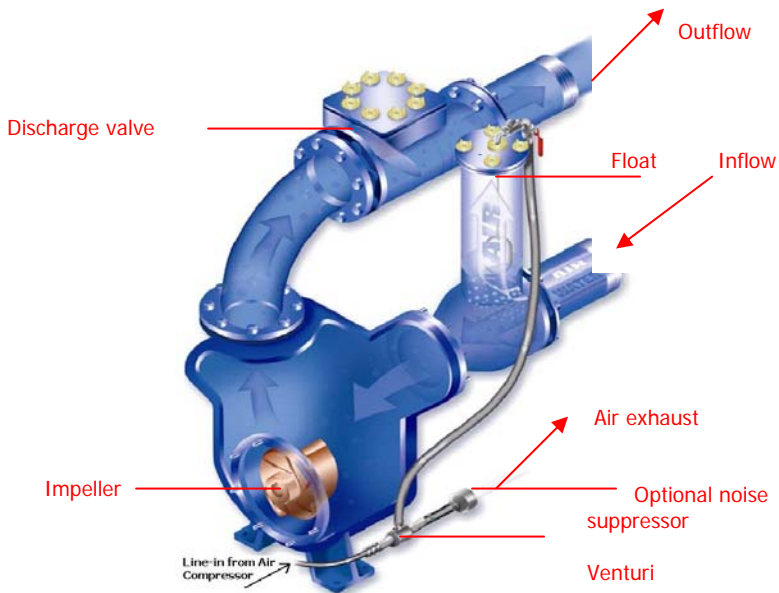

** Some features not available on all models*

ENVIOPRIME® system

Thompson's exclusive ENVIOPRIME® dry-priming system works in conjunction with the compressor/venturi priming system to prevent blow-by, such as sewage and waste, from discharging onto the ground. The system works automatically, evacuating the air from the suction line during startup, as well as any air or gases introduced into the suction line during the pumping process.

Features and Benefits

- Handles large volumes of air, producing quicker priming times.
- Eliminates need for a venturi waste hose
- Extends the life of the pump by separating air and water, keeping the venturi from clogging and shutting down the system.
- Allows for optional noise suppressor
- This innovative system, along with high efficiency impellers, lessens power requirements resulting in reduced operating costs.



6" ENVIROPRIME® Compressor-Assisted Trash Pump 6TSC-DJDST-4045D-MC



6TSC-DJDST-4045D-MC Dimensions

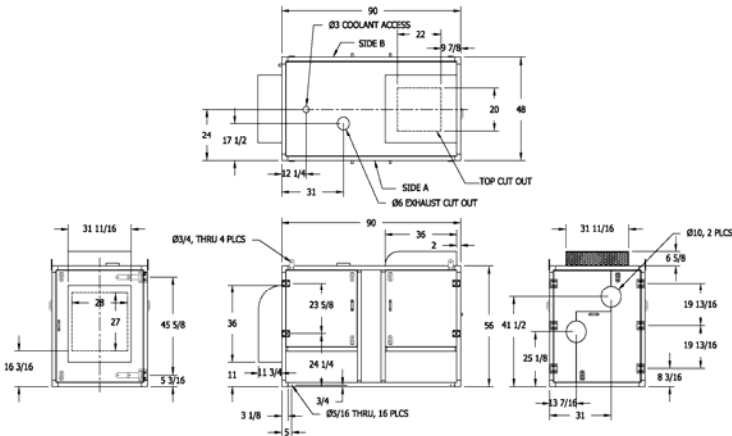

6TSC-DJDST-4045D -MC Performance Curve

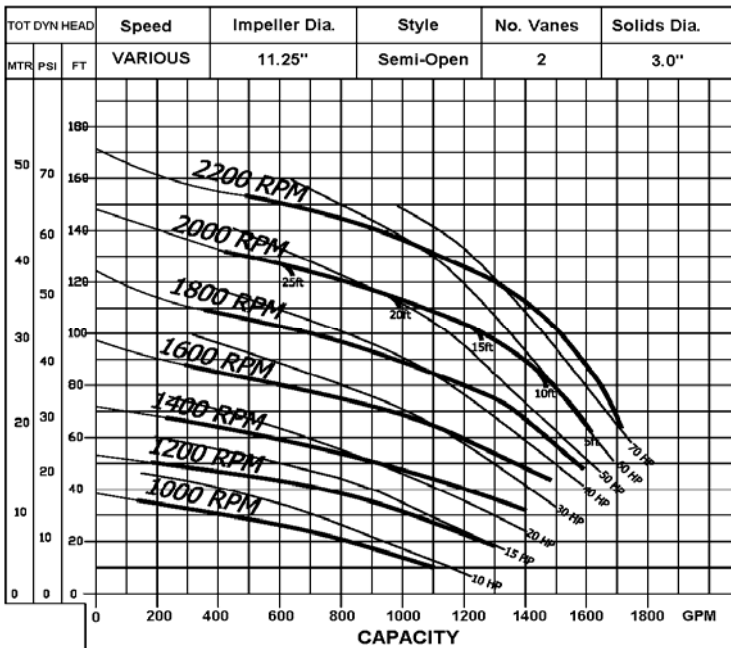

Materials of Construction

- Pump Casing:** Heavy-duty class 30 cast-iron with built-in volute
- Impeller:** Dynamically balanced, two-vane, non-clogging, semi-open with full rear shroud, ductile iron with rear-equalizing vanes to reduce axial loading and prolong seal and bearing life; Diameter 11.25"
- Mechanical Seal:** Grease or oil lubricated with Tungsten Carbide rotating and stationary seal faces. Single inside mounted, non-pusher type with self-adjusting elastomeric bellows. Other components are 304 stainless steel and Viton.
- Head:** Rugged, back pull out design, heavy-duty class 30 cast iron with tapered bore design.
- Bearings & frame:** Heavy-duty grease lubricated to carry both axial and radial loads. Frame, heavy-duty class 30 cast iron
- Wear plate:** Replaceable, class 30 cast iron with abrasion resistant rubber facing to extend service life
- Shaft:** Carbon steel and fitted with a 304 stainless steel shaft sleeve

Engine Specifications

- Engine:** John Deere 4045D, 62 hp @ 1,800 rpm
- Type:** 4-cylinder, in-line, 4-cycle, water-cooled, naturally aspirated, direct-injected, Tier II diesel
- Standard Equipment:** Alternator, radiator, muffler, and exhaust stack with rain protection
- Displacement:** 276 cubic inches
- Fuel Economy:** .379 lb/hp-hr @ 1,800 rpm
- Safety Shutdowns:** Low oil pressure; high coolant temperature

Unit Specifications

- Fuel Tank Capacity:** 100 US gallons
- Fuel Consumption:** 2.36 gallons per hour
- Maximum Operating Speed:** 1,800 rpm
- Maximum Operating Temperature:** 212°F
- Maximum Working Pressure:** 81 psi
- Maximum Suction Lift:** 28 feet
- Maximum Casing Pressure:** 112 psi

In the interest of product improvement, Thompson Pump & Manufacturing reserves the right to change specifications without incurring any obligation for equipment previously or subsequently sold. Capacity, Head and Pump Curve are for comparative purposes. Consult engineering data for exact capabilities.
4620 City Center Drive, Port Orange, FL, 32129, USA (800) 767-7310 * Fax (386) 761-0362

Email: sales@thompsonpump.com * www.thompsonpump.com

