



4" Vacuum-Assisted Dry Prime Trash Pump 4TSV-DJDST-4045D

The 4TSV-DJDST-4045D, vacuum-assisted dry prime trash pump, combines the rugged Thompson heavy-duty wet priming centrifugal open trash/sewage pump and an auxiliary vacuum pump to deliver the fastest priming in the industry. This Super Suction vacuum-assisted pump is used for sewer bypasses, excavation dewatering, wellpoint systems and sock underdrains. The 4TSV-DJDST-4045D provides continuous pumping of liquids mixed with a high percentage of air and can handle high abrasives or solids in suspension. Thompson *Super Suction* vacuum-assisted pumps are especially useful in high lift situations not suitable for standard trash pumps.

Features

- Standard engine – John Deere 4045D
A variety of diesel engines available.
- Fully automatic, dry priming to 28 feet
- Moderate heads to 90 feet; Maximum flows to 930 gpm
- Compact unit available with modular frame
- Maximum operating time is 38 hours @ 1,800 rpm
- Super Suction vacuum-assisted priming system

Air cyclone vapor recovery system to prevent discharge of contaminants

Air separator assembly

Suction port above the eye of the impeller to allow for automatic repriming should the vacuum system fail

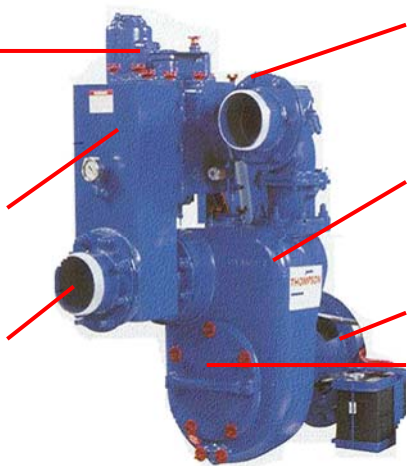

Discharge priming valve

Cast iron pump with maximum solids capacity of 3"

Cast iron intermediate bearing housing

Large clean-out port, which allows removal of the impeller, wear plate and mechanical seal without disturbing the piping

SUPER SUCTION VACUUM-ASSISTED PRIMING SYSTEM

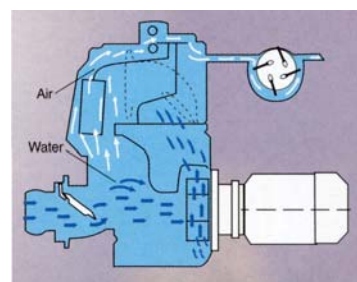

Thompson's exclusive Super Suction vacuum-assisted system works with a self-priming pump to provide the fastest priming in the industry. Water and air passes through a cross section tank and then into the vacuum pump forcing the water to rise in the separation tank until a balance point is reached.

Features and Benefits

- Provides fastest priming system in portable pump dewatering industry
- Prevents discharge of pumping effluent onto the ground
- Eliminates need for a waste hose
- Eliminates need to fill up pump housing with water to obtain original prime at start-up



4" Vacuum-Assisted Dry Prime Trash Pump 4TSV-DJDST-4045D

4TSV-DJDST-4045D Dimensions

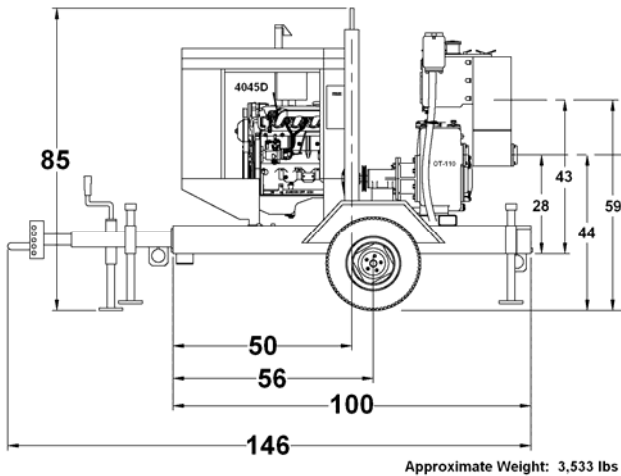

Materials of Construction

Pump Casing: Heavy-duty class 30 cast-iron with built-in volute

Impeller: Dynamically balanced, two-vane, non-clogging, semi-open, ductile iron, with rear-equalizing vanes to reduce axial loading and prolong seal and bearing life. Diameter 9.74"

Mechanical Seal: Grease or oil lubricated with Tungsten Carbide rotating and stationary seal faces. Single inside mounted, non-pusher type with self-adjusting elastomeric bellows. All other components are 304 stainless steel and Viton.

Head: Rugged, back pull out design, heavy-duty class 30 cast iron with tapered bore design

Bearings and Frame: Heavy-duty grease lubricated; Frame is heavy-duty class 30 cast iron

Shaft: High quality carbon steel

Suction check Valve: Built-in weighted, full-flow valve to eliminate re-priming with each cycle.

Wear Plate: Replaceable, class 30 cast iron with abrasion resistant rubber facing to extend service life

4TSV-DJDST-4045D Performance Curve

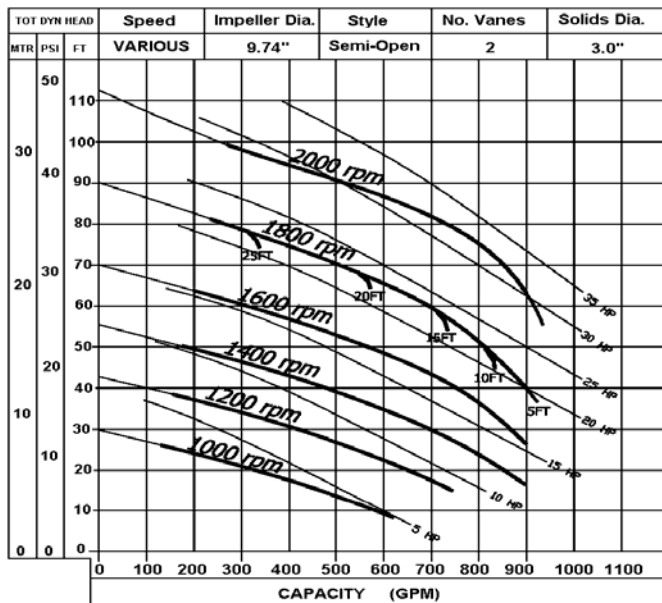

Engine Specifications

Engine: John Deere 4045D, 62 hp @ 1,800 rpm

Type: 4-cylinder, in-line, 4-cycle, water-cooled, natural aspiration, direct-injected, Tier II diesel

Standard Equipment: Alternator, radiator, muffler, and exhaust stack with rain protection

Displacement: 276 cubic inches

Fuel Economy: .379 lb/hp-hr @ 1,800 rpm

Safety Shutdowns: High coolant temperature; Low oil pressure

Unit Specifications

Fuel Tank Capacity: 60 US gallons

Fuel Consumption: 1.58 gallons per hour

Maximum Operating Speed: 1,800 rpm

Maximum Operating Temperature: 212°F

Maximum Working Pressure: 58 psi

Maximum Suction Lift: 28 feet

Maximum Casing Pressure: 73 psi

In the interest of product improvement, Thompson Pump & Manufacturing reserves the right to change specifications without incurring any obligation for equipment previously or subsequently sold. Capacity, Head and Pump Curve are for comparative purposes. Consult engineering data for exact capabilities.
4620 City Center Drive, Port Orange, FL, 32129, USA (800) 767-7310 * Fax (386) 761-0362

Email: sales@thompsonpump.com * www.thompsonpump.com

