



# 4" SUREPRIME Open Trash/Sewage Pump

## 4TS-DJDST-4045D

Thompson open trash/sewage pumps with the *SurePrime* self-priming centrifugal pump end are ideal for construction dewatering and sewer bypass applications. Specified for handling large solids and/or abrasive material at high heads, the 4TS-DJDST-4045D outperforms other centrifugal trash pumps on the market and costs less to operate. The quality and dependability engineered into each Thompson heavy-duty trash pump provides the high performance needed to get the job done efficiently and effectively.

### Features

- Standard engine – John Deere 4045D  
Also available with Deutz engines
- Fully automatic, dry priming to 28 feet.
- Moderate heads to 90 feet; Maximum flows to 930 gpm
- Solids handling to 3"
- *SurePrime* centrifugal self-priming pump end assures reliable priming performance
- Heavy-duty cast iron construction for long life
- Quick start-up self-priming and automatic re-priming
- Available with modular frame and removable drop-on sound attenuated canopy
- Maximum operating time is 41 hours @ 1,800 rpm

**SUREPRIME**  
SELF-PRIMING CENTRIFUGAL PUMP END

### Working Principle

The impeller rotates and creates a vacuum drawing air into the pump where it is mixed with the liquid contained in the pump casing. The air/liquid mixture is driven into the priming chamber where the air separates and is expelled through the delivery port while the liquid, due to its higher density, falls back and is re-circulated.

When the suction line has evacuated the air, the pump is primed and operates as a standard centrifugal pump. The check valve mounted in the pump suction port ensures that sufficient liquid remains in the pump casing for re-priming. In addition, the check valve prevents the liquid from draining out of the suction line, so at restart no time is lost for re-priming.

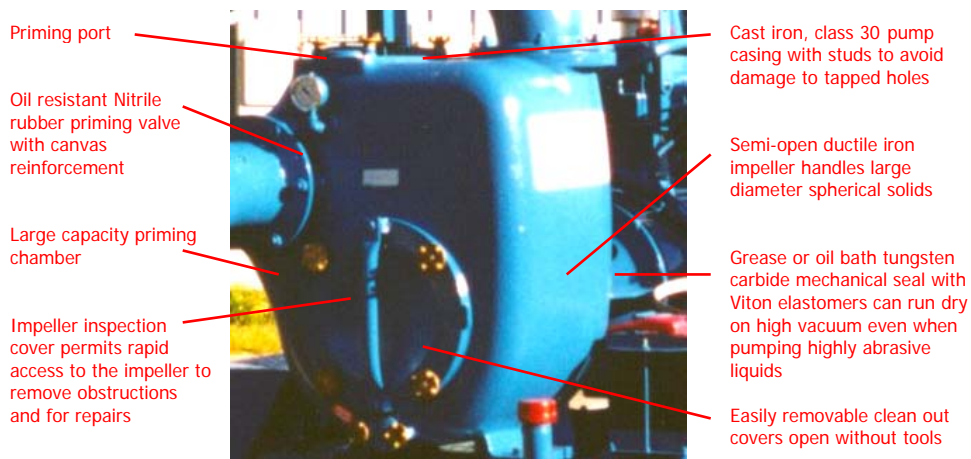

# 4" SUREPRIME Open Trash/Sewage Pump 4TS-DJDST-4045D

## 4TS-DJDST-4045D Dimensions

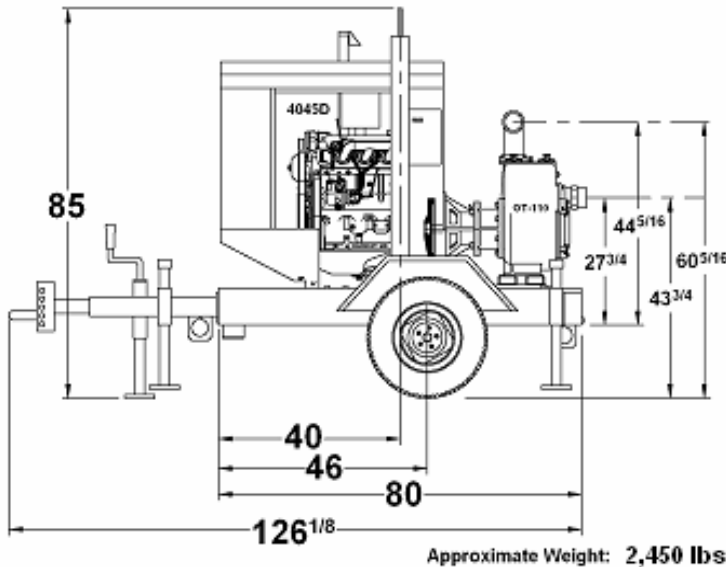

## Materials of Construction

- Pump Casing:** Heavy-duty class 30 cast-iron with built-in volute.
- Impeller:** Dynamically balanced, two-vane, non-clogging, semi-open with full rear shroud, ductile iron, with rear-equalizing vanes to reduce axial loading and prolong seal and bearing life. Diameter 9.74"
- Mechanical Seal:** Grease or oil lubricated with Tungsten Carbide rotating and stationary seal faces. Single inside mounted, non-pusher type with self-adjusting elastomeric bellows.
- Head:** Rugged, back pull out design, heavy-duty class 30 cast iron with tapered bore design.
- Bearings & Frame:** Heavy-duty grease lubricated to carry both axial and radial loads. Frame, heavy-duty class 30 cast iron.
- Shaft:** Carbon steel and fitted with a 304 stainless steel shaft sleeve.
- Suction Check Valve:** Built-in weighted, full-flow valve to eliminate re-priming with each cycle.
- Wear Plate:** Replaceable, class 30 cast iron with abrasion resistant rubber facing to extend to extend service life

## 4TS-DJDST-4045D Performance Curve

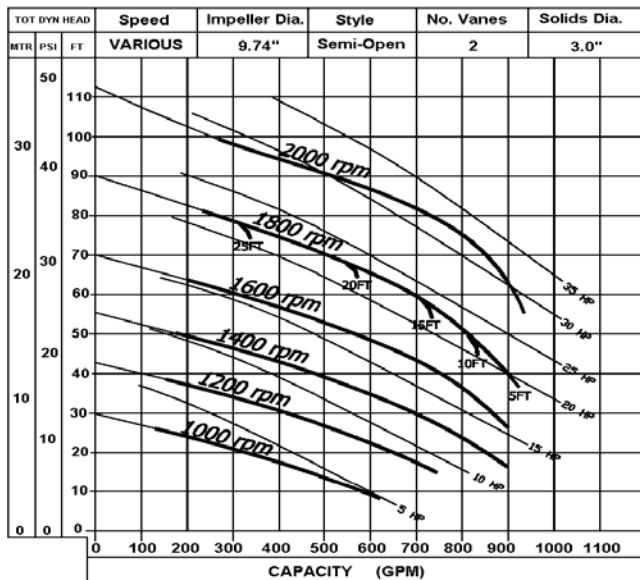

## Engine Specifications

- Engine:** John Deere 4045D, 62 hp @ 1,800 rpm
- Type:** 4-cylinder, in-line, 4-cycle, water-cooled, naturally aspirated, direct-injected, Tier II diesel
- Standard Equipment:** Alternator, radiator, muffler, and exhaust stack with rain protection.
- Displacement:** 276 cubic inches
- Fuel Economy:** .379 lb/hp-hr @ 1,800 rpm
- Safety Shutdowns:** High coolant temperature and low oil pressure.

## Unit Specifications

- Fuel Tank Capacity:** 50 US gallons
- Fuel Consumption:** 1.21 gallons per hour
- Maximum Operating Speed:** 1,800 rpm
- Maximum Operating Temperature:** 212°F
- Maximum Working Pressure:** 58 psi
- Maximum Suction Lift:** 28 feet
- Maximum Casing Pressure:** 73 psi

In the interest of product improvement, Thompson Pump & Manufacturing reserves the right to change specifications without incurring any obligation for equipment previously or subsequently sold. Capacity, Head and Pump Curve are for comparative purposes. Consult engineering data for exact capabilities.  
4620 City Center Drive, Port Orange, FL, 32129, USA (800) 767-7310 \* Fax (386) 761-0362  
Email: [sales@thompsonpump.com](mailto:sales@thompsonpump.com) \* [www.thompsonpump.com](http://www.thompsonpump.com)

