



# 4" Solids Handling Vacuum-Assisted Jet Pump 4JSVD-DJDST-4045T-M

With its heavy-duty cast-iron construction and fast priming capabilities, this Super Suction solids handling jet pump leads the industry in construction, industrial and mining applications. The Thompson 4JSVD-DJDST-4045T-M is designed for high flows to 1,200 gpm and heads to 255 feet making it perfect for sewage bypass pumping or general construction dewatering.

## Features

- Standard engine –John Deere 4045T
- Fully automatic, dry priming to 28 feet.
- High heads to 255 feet
- Maximum flows to 1,200 gpm
- Solids handling to 3"
- Compact unit available with modular frame or removable drop-on Silent Knight® sound enclosure
- Maximum operating time is 35 hours @ 1,800 rpm

## Super Suction Features & Benefits

- Provides fastest priming system in portable pump dewatering industry
- Prevents discharge of pumping effluent onto the ground
- Eliminates need for a waste hose
- Eliminates need to fill up pump housing with water to obtain original prime at start-up

Air cyclone vapor recovery system to prevent discharge of contaminants

Discharge Priming Valve

High capacity, centrifugal pump.



High volume air separation chamber

## SUPER SUCTION

VACUUM-ASSISTED PRIMING SYSTEM

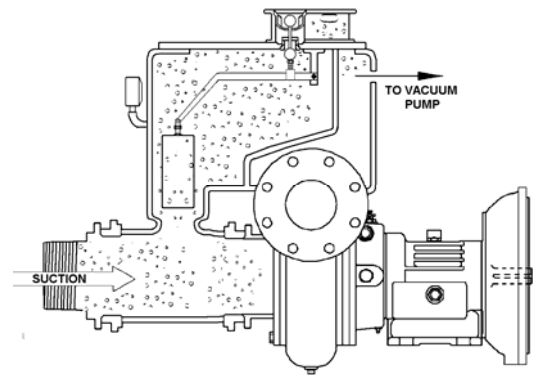

Thompson's exclusive Super Suction vacuum-assisted system works with a self-priming pump to provide the fastest priming in the industry. Water and air passes through a cross section tank and then into the vacuum pump forcing the water to rise in the separation tank until a balance point is reached.



# 4" Solids Handling Vacuum-Assisted Jet Pump 4JSVD-DJDST-4045T-M

## 4JSVD-DJDST-4045T-M Dimensions

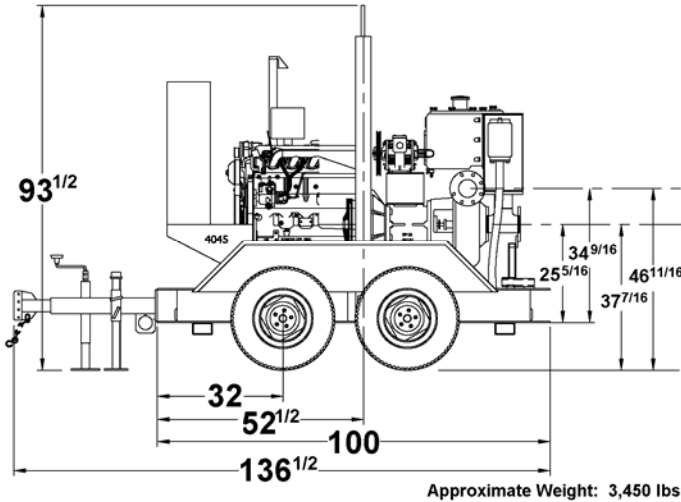

## Materials of Construction

**Pump Casing:** Heavy-duty class 30 cast-iron  
**Impeller:** Dynamically balanced, non-clogging, enclosed, class 30 cast iron, with rear-equalizing vanes to reduce axial loading and prolong seal and bearing life; Diameter 14"  
**Mechanical Seal:** 2.5" run-dry, oil or grease lubricated with Tungsten Carbide rotating and Silicon Carbide stationary seal faces. Single inside mounted, non-pusher type with self-adjusting elastomeric bellows. All other components are 304 stainless steel and nitrile.  
**Head:** Rugged, back pull out design, heavy-duty class 30 cast iron with tapered bore design  
**Bearings & Frame:** Heavy-duty grease lubricated to carry both axial and radial loads. Frame is heavy-duty class 30 cast-iron  
**Shaft:** High quality 'stress-proof' steel and fitted with a renewable 416 stainless steel sleeve

## Engine Specifications

**Engine:** John Deere 4045T, 87 hp @ 1,800 rpm  
**Type:** 4-cylinder, in-line, 4-cycle, water-cooled, natural aspiration, direct-injected, Tier II diesel  
**Standard Equipment:** Alternator, radiator, muffler and exhaust stack with rain protection  
**Displacement:** 275 cubic inches  
**Fuel Economy:** .381 lb/hp-hr @ 1,800 rpm  
**Safety Shutdowns:** High coolant temperature; Low oil pressure

## Unit Specifications

**Fuel Tank Capacity:** 114 US gallons  
**Fuel Consumption:** 3.17 gallons per hour  
**Maximum Operating Speed:** 1,800 rpm  
**Maximum Operating Temperature:** 212°F  
**Maximum Working Pressure:** 175 psi  
**Maximum Suction Lift:** 28 feet  
**Maximum Casing Pressure:** 350 psi

## 4JSVD-DJDST-4045T-M Performance Curve

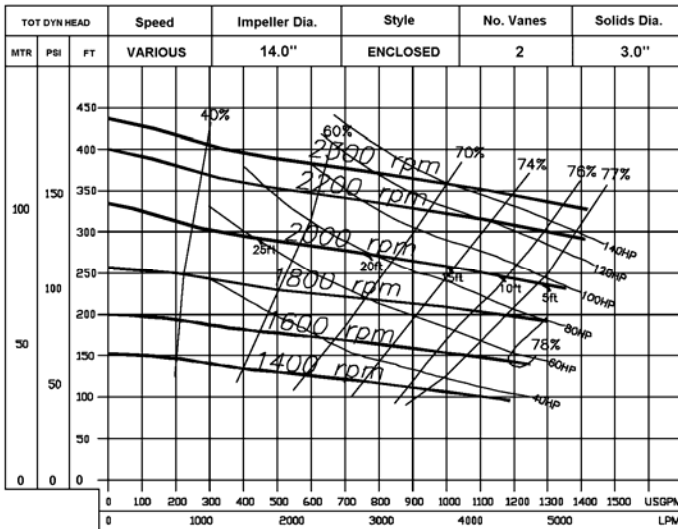

In the interest of product improvement, Thompson Pump & Manufacturing reserves the right to change specifications without incurring any obligation for equipment previously or subsequently sold. Capacity, Head and Pump Curve are for comparative purposes. Consult engineering data for exact capabilities.  
 4620 City Center Drive, Port Orange, FL, 32129, USA (800) 767-7310 \* Fax (386) 761-0362

Email: [sales@thompsonpump.com](mailto:sales@thompsonpump.com) \* [www.thompsonpump.com](http://www.thompsonpump.com)

