

4" High-Pressure ENVIOPRIME® Jet Pump 4JCA-DJDST-4045D

With its heavy-duty cast-iron construction and high-pressure capability, this end-suction centrifugal pump leads the industry in construction, industrial and marine applications. The Thompson 4JCA-DJDST-4045D ENVIOPRIME® Jet Pump is designed for moderate flows to 920 gpm and high heads to 330 feet making it perfect for jetting in wellpoint systems.

Features

- Standard engine – John Deere 4045D.
- Fully automatic, dry priming to 28 feet.
- High heads to 330 feet; Maximum flows to 920 gpm; spherical solids handling to .5"
- Maximum operating time is 18 hours @ 2,000 rpm
- ENVIOPRIME® compressor-assisted priming system prevents blow-by allowing pump to be environmentally safe

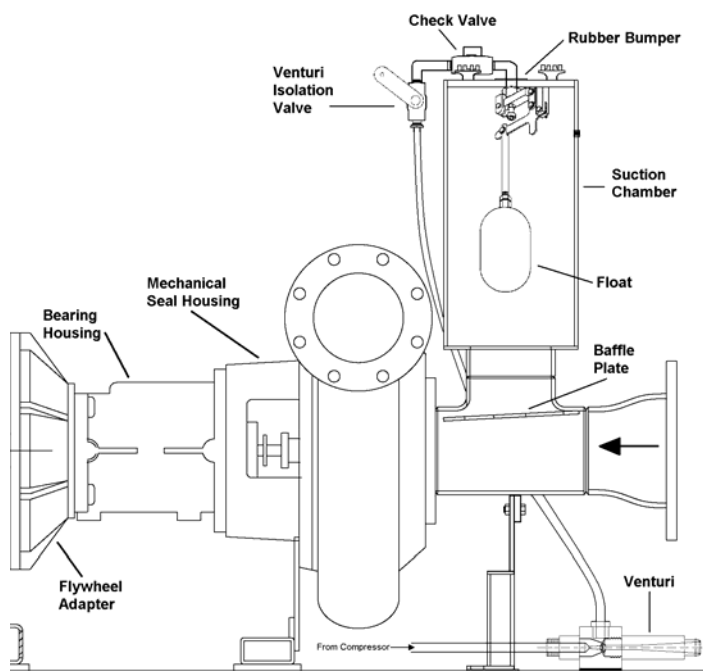

ENVIOPRIME® system

Thompson's exclusive ENVIOPRIME® dry-priming system works in conjunction with the compressor/venturi priming system to prevent blow-by, such as sewage and waste, from discharging onto the ground. The system works automatically, evacuating the air from the suction line during startup, as well as any air or gases introduced into the suction line during the pumping process.

Features and Benefits

- Handles large volumes of air, producing quicker priming times.
- Eliminates need for a venturi waste hose
- Extends the life of the pump by separating air and water, keeping the venturi from clogging and shutting down the system.
- Allows for optional noise suppressor
- This innovative system, along with high efficiency impellers, lessens power requirements resulting in reduced operating costs.



4" High-Pressure ENVIROPRIME® Jet Pump 4JCA-DJDST-4045D

4JCA-DJDST-4045D Dimensions

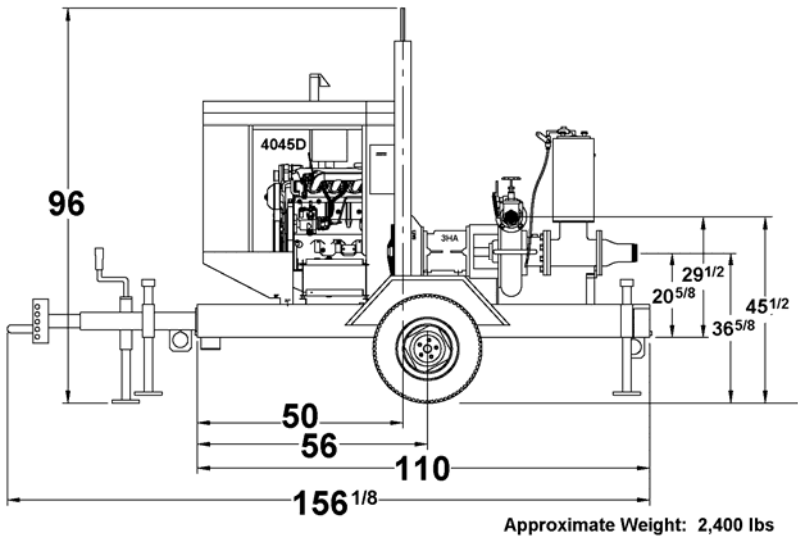

Materials of Construction

Pump Casing: Rugged, heavy-duty class 30 cast-iron
Shaft: 'Stress-proof' SAE 1144 steel and fitted with a renewable SAE 660 bronze shaft sleeve.
Impeller: Dynamically balanced, enclosed, SAE 40 bronze, with rear-equalizing vanes to reduce axial loading and prolong seal and bearing life. Diameter 15.22"
Suction Wear Ring: Replaceable, SAE 660 bronze.
Mechanical Seal: 2.5" dry-running, grease or oil lubricated with Tungsten Carbide rotating and Silicon Carbide stationary seal faces. Single inside mounted, non-pusher type with self-adjusting elastomeric bellows. All other components are 304 stainless steel and nitrile.
Head: Rugged, back pull out design, heavy-duty class 30 cast iron with tapered bore design.
Bearings: Heavy-duty grease lubricated to carry both axial and radial loads.
Bearing Frame: Heavy-duty class 30 cast iron

Engine Specifications

Engine: John Deere 4045D, 67 hp @ 2,000 rpm
Type: 4-cylinder, in-line, 4-cycle, water-cooled, natural aspiration, direct-injected, Tier II diesel
Standard Equipment: Alternator, radiator, muffler, and exhaust stack with rain protection.
Displacement: 276 cubic inches
Fuel Economy: .378 lb/hp-hr @ 2,000 rpm
Safety Shutdowns: High coolant temperature; Low oil pressure

4JCA-DJDST-4045D Performance Curve

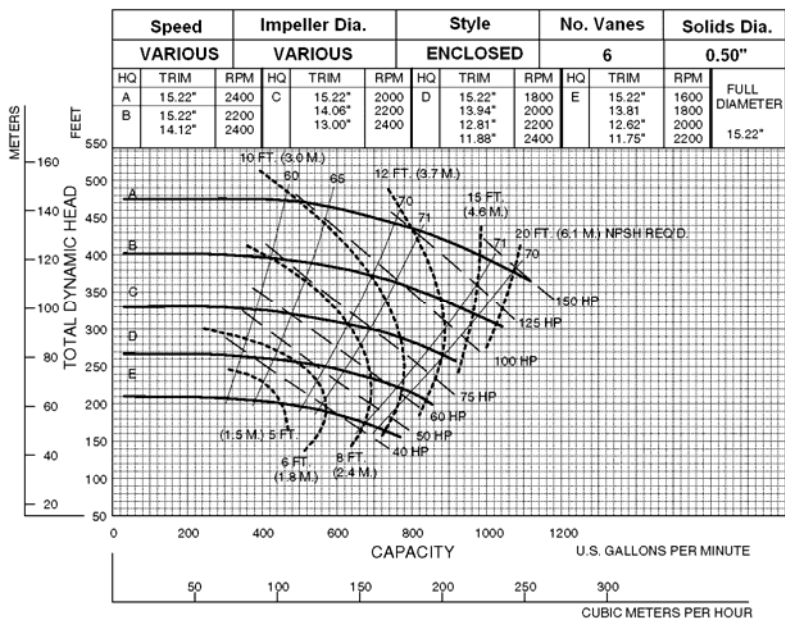

Unit Specifications

Fuel Tank Capacity: 65 US gallons
Fuel Consumption: 3.68 gallons per hour
Maximum Operating Speed: 2,000 rpm
Maximum Operating Temperature: 212° F
Maximum Working Pressure: 215 psi
Maximum Suction Lift: 28 feet
Maximum Casing Pressure: 350 psi

In the interest of product improvement, Thompson Pump & Manufacturing reserves the right to change specifications without incurring any obligation for equipment previously or subsequently sold. Capacity, Head and Pump Curve are for comparative purposes. Consult engineering data for exact capabilities.
 4620 City Center Drive, Port Orange, FL, 32129, USA (800) 767-7310 * Fax (386) 761-0362

Email: sales@thompsonpump.com * www.thompsonpump.com

