

4" High-Pressure Jet Pump

4JA-DDST-4-914

With its heavy-duty cast-iron construction and high-pressure capability, this end-suction centrifugal pump leads the industry in construction, industrial and marine applications. The Thompson 4JA-DDST-4-914 Jet Pump is designed for high flows to 920 gpm and high heads to 330 feet making it perfect for jetting in wellpoint systems.

Features

- Standard engine – Deutz F4L914.
Also available with a John Deere engine
- Fully automatic, dry priming to 28 feet
- High heads to 330 feet; Maximum flows to 920 gpm; Spherical solids handling to .5"
- Maximum operating time is 17 hours @ 2,000 rpm

Working Principle

The pump achieves and maintains its prime with the aid of an on-board hand primer. The impeller and volute are designed to handle clear liquid with a slight amount of solids. As the liquid passes through the volute, it is sent out a smaller diameter discharge port. The smaller port increases the pressure as the liquid leaves the pump, creating the jetting feature.

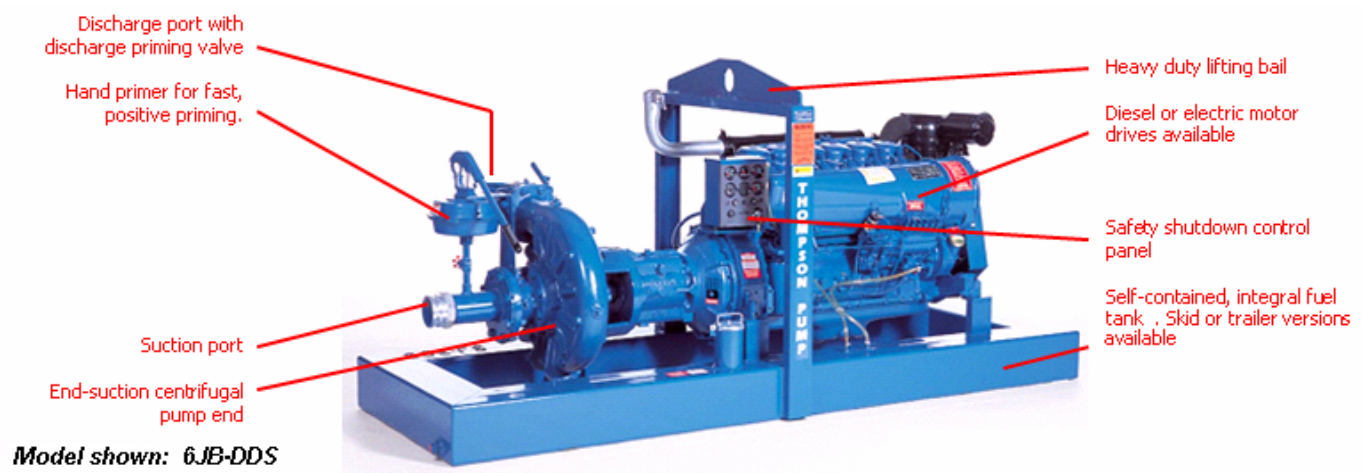

4" Clear Liquid Handling Pump 4JA-DDST-4-914

4JA-DDST-4-914 Dimensions

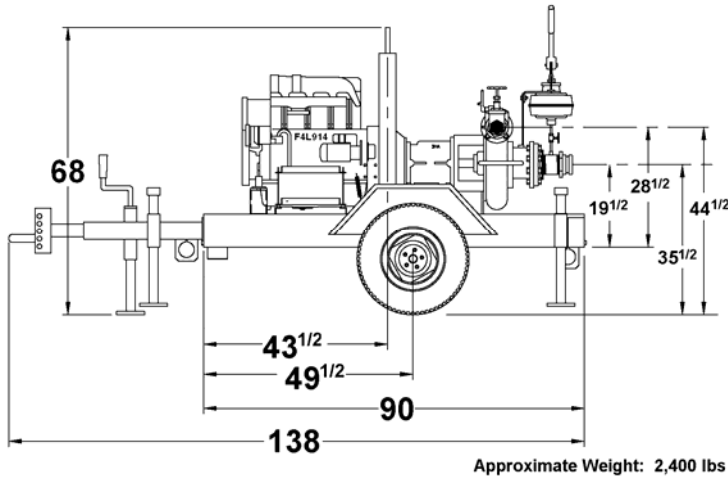

Materials of Construction

- Pump Casing:** Rugged, heavy-duty class 30 cast-iron
- Shaft:** 'Stress-proof' SAE 1144 steel and fitted with a renewable SAE 660 bronze shaft sleeve.
- Impeller:** Dynamically balanced, enclosed, SAE 40 bronze, with rear-equalizing vanes to reduce axial loading and prolong seal and bearing life, Diameter 15.22"
- Suction Wear Ring:** Replaceable, SAE 660 bronze.
- Mechanical Seal:** 2.5" dry-running, grease or oil lubricated with Tungsten Carbide rotating and Silicon Carbide stationary seal faces. Single inside mounted, non-pusher type with self-adjusting elastomeric bellows. All other components are 304 stainless steel and nitrile.
- Head:** Rugged, back pull out design, heavy-duty class 30 cast iron
- Bearings:** Heavy-duty grease lubricated to carry both axial and radial loads.
- Bearing Frame:** Heavy-duty class 30 cast iron

4JA-DDST-4-914 Performance Curve

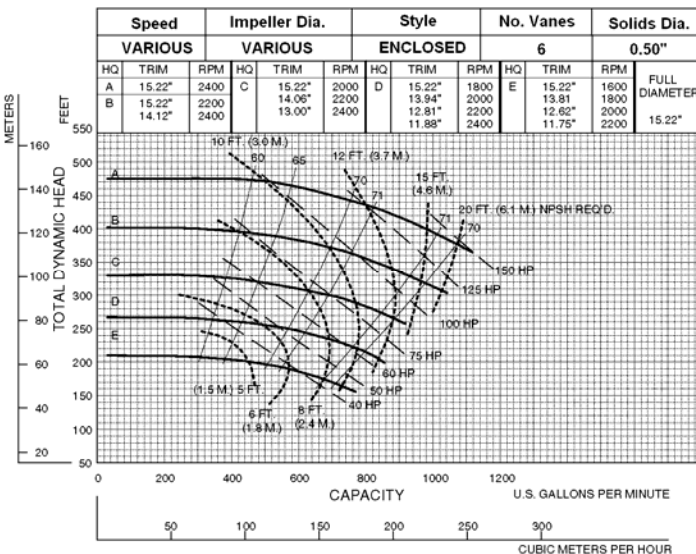

Engine Specifications

- Engine:** Deutz F4L914, 72 hp @ 2,000 rpm
- Type:** 4-cylinder, in-line, 4-cycle, direct-injected diesel
- Standard Equipment:** Alternator, radiator, muffler, and exhaust stack with rain protection.
- Displacement:** 263.3 cubic inches
- Fuel Economy:** .377 lb/hp-hr @ 2,000 rpm
- Safety Shutdowns:** High coolant temperature; Low oil pressure.

Unit Specifications

- Fuel Tank Capacity:** 55 US gallons
- Fuel Consumption:** 3.15 gallons per hour
- Maximum Operating Speed:** 2,000 rpm
- Maximum Operating Temperature:** 212°F
- Maximum Working Pressure:** 215 psi
- Maximum Suction Lift:** 28 feet
- Maximum Casing Pressure:** 350 psi

In the interest of product improvement, Thompson Pump & Manufacturing reserves the right to change specifications without incurring any obligation for equipment previously or subsequently sold. Capacity, Head and Pump Curve are for comparative purposes. Consult engineering data for exact capabilities.
4620 City Center Drive, Port Orange, FL, 32129, USA (800) 767-7310 * Fax (386) 761-0362

Email: sales@thompsonpump.com * www.thompsonpump.com

