

# 4" Solids Handling ENVIROPRIME® Pump 4HTC-DDST-3-2011

With its heavy-duty cast-iron construction, ability to dry-prime and re-prime automatically, this compressor-assisted dry prime trash pump handles construction, industrial and wastewater applications effectively. The Thompson 4HTC-DDST-3-2011 ENVIROPRIME® Compressor-Assisted Pump is designed for flow rates to 650 gpm, moderate heads to 105 feet and solids handling to 2", making it perfect for sewage bypass pumping or general construction dewatering where moderate air handling is required.

## Features

- Standard engine – Deutz F3L2011  
Also available with other diesel engines
- Fully automatic, dry priming to 28 feet.
- Moderate heads to 105 feet. Maximum flows to 650 gpm.
- Compact unit available with modular frame.
- Maximum operating time is 44 hours @ 1,800 rpm
- ENVIROPRIME® compressor-assisted priming system prevents blow-by allowing pump to be environmentally safe.

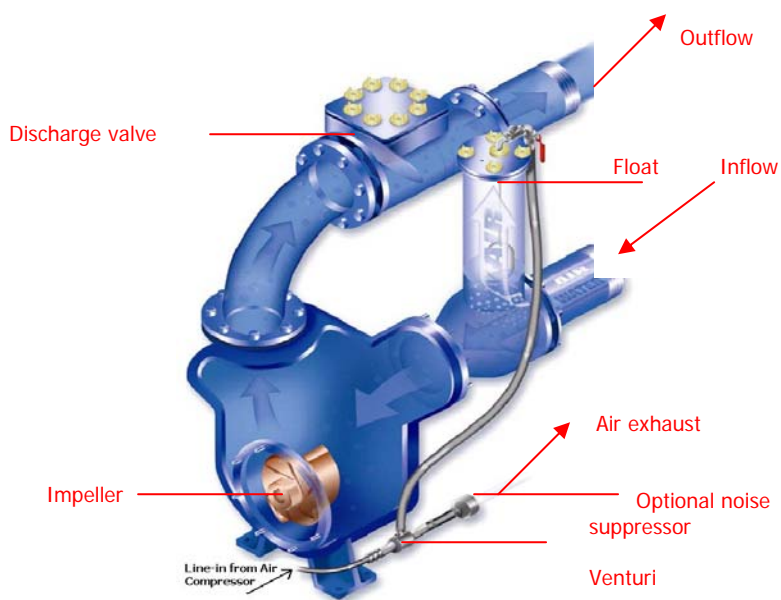

*\* Some features not available on all models*

## ENVIROPRIME® system

Thompson's exclusive ENVIROPRIME® dry-priming system works in conjunction with the compressor/venturi priming system to prevent blow-by, such as sewage and waste, from discharging onto the ground. The system works automatically, evacuating the air from the suction line during startup, as well as any air or gases introduced into the suction line during the pumping process.

## Features and Benefits

- Handles large volumes of air, producing quicker priming times.
- Eliminates need for a venturi waste hose
- Extends the life of the pump by separating air and water, keeping the venturi from clogging and shutting down the system.
- Allows for optional noise suppressor
- This innovative system, along with high efficiency impellers, lessens power requirements resulting in reduced operating costs.

**THOMPSON  
PUMP**  
EXPERIENCE INNOVATION

# 4" Solids Handling ENVIROPRIME® Pump 4HTC-DDST-3-2011

## 4HTC-DDST-3-2011 Dimensions

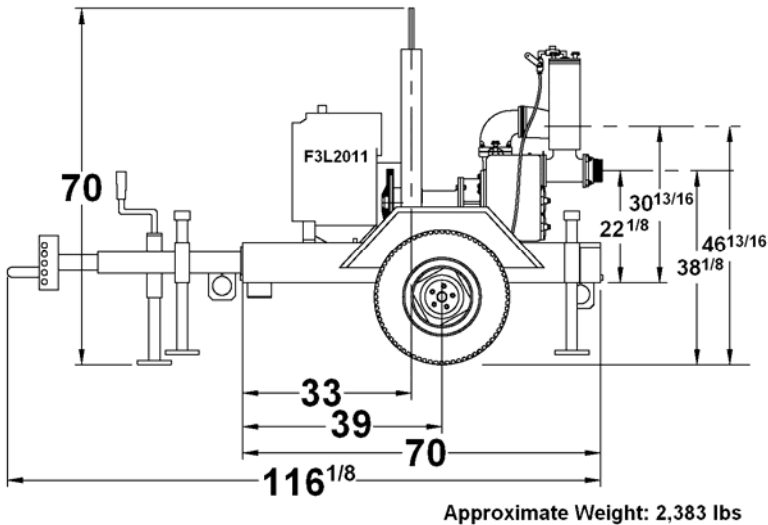

## Materials of Construction

- Pump Casing:** Heavy-duty class 30 cast-iron with built-in volute.
- Impeller:** Dynamically balanced, two-vane, non-clogging, semi-open with full rear-shroud, ductile iron, with rear-equalizing vanes to reduce axial loading and prolong seal and bearing life. Diameter 9.74"
- Mechanical Seal:** Oil or grease lubricated and equipped with Tungsten Carbide rotating and stationary seal faces. All other seal components are 304 stainless steel and Viton.
- Head:** Rugged, back pull out design, heavy-duty class 30 cast iron with tapered bore design.
- Bearings & Frame:** Heavy-duty grease lubricated bearings to carry both axial and radial loads. Class 30 cast iron frame
- Shaft:** Constructed of SAE 4140 alloy steel and fitted with a 304 stainless steel shaft sleeve.
- Wear Plate:** Replaceable, class 30 cast iron with abrasion resistant rubber facing to extend service life

## 4HTC-DDST-3-2011 Performance Curve

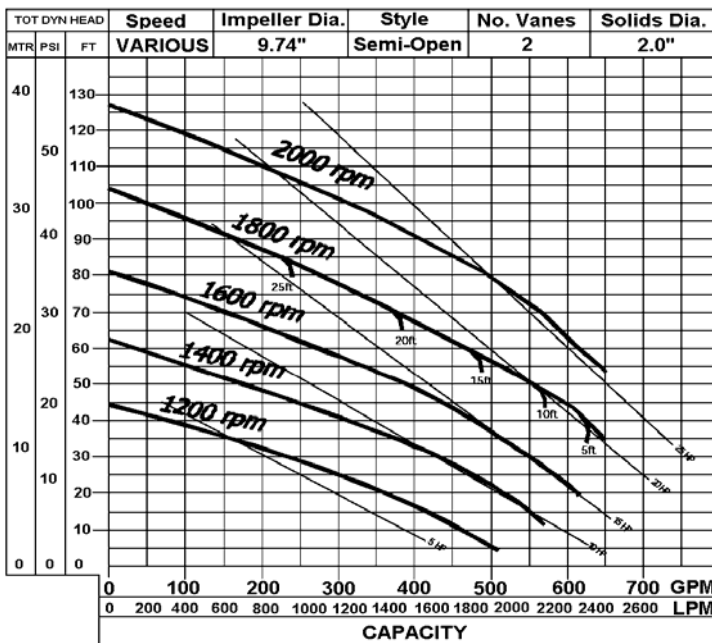

## Engine Specifications

- Engine:** Deutz F3L2011, 35 HP @ 1,800 rpm
- Type:** 3-cylinder, in-line, 4-cycle, direct-injected diesel.
- Standard Equipment:** Alternator, radiator, muffler and exhaust stack with rain protection
- Displacement:** 142.2 cubic inches
- Fuel Economy:** 0.362 lb/hp-hr @ 1,800 RPM
- Safety Shutdowns:** Low oil pressure; High coolant temperature

## Unit Specifications

- Fuel Tank Capacity:** 55 US gallons
- Fuel Consumption:** 1.25 gallons per hour
- Maximum Operating Speed:** 1,800 rpm
- Maximum Operating Temperature:** 212°F
- Maximum Working Pressure:** 68 psi
- Maximum Suction Lift:** 28 feet
- Maximum Casing Pressure:** 82 psi

In the interest of product improvement, Thompson Pump & Manufacturing reserves the right to change specifications without incurring any obligation for equipment previously or subsequently sold. Capacity, Head and Pump Curve are for comparative purposes. Consult engineering data for exact capabilities.  
4620 City Center Drive, Port Orange, FL, 32129, USA (800) 767-7310 \* Fax (386) 761-0362  
Email: [sales@thompsonpump.com](mailto:sales@thompsonpump.com) \* [www.thompsonpump.com](http://www.thompsonpump.com)

