



# 4" Wet-Prime Trash Pump 4HT-DDST-3-2011

With its heavy-duty cast-iron construction, ability to self-prime and re-prime automatically, this trash pump leads the industry in construction, industrial and wastewater applications. The 4HT-DDST-3-2011 provides flow rates up to 650 gpm and can handle spherical solids up to 2" making it perfect for sewage bypass pumping or dewatering excavations.

## Features

- Standard engine - Deutz F3L2011  
Also available with Lombardini model.
- Fully automatic, dry priming to 28 feet.
- Moderate heads to 105 feet.  
Maximum flows to 650 gpm.
- Compact unit available with detachable trailer.
- Maximum operating time is 40 hours @ 1,800 rpm

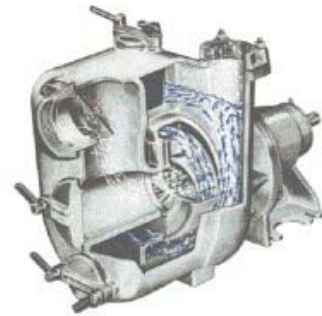

The impeller rotates and creates a vacuum drawing air into the pump where it is mixed with the liquid contained in the pump casing. The air/liquid mixture is driven into the priming chamber where the air separates and is expelled through the delivery port while the liquid, due to its higher density, falls back and is re-circulated.

When the suction line has evacuated the air, the pump is primed and operates as a standard centrifugal pump. The check valve mounted in the pump suction port ensures that sufficient liquid remains in the pump casing for re-priming. In addition, the check valve prevents the liquid from draining out of the suction line, so at restart no time is lost for re-priming.

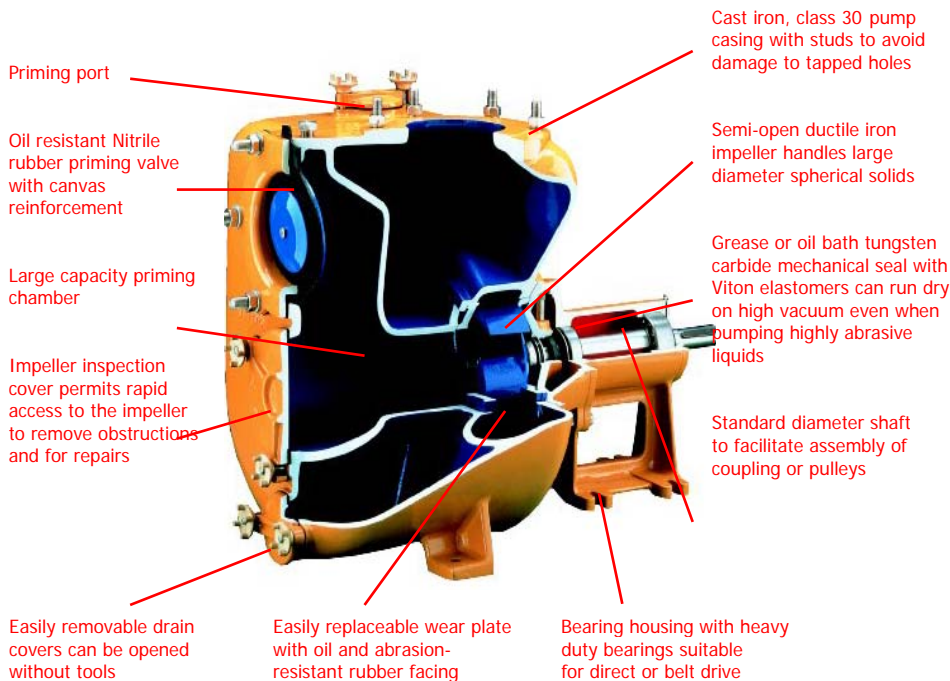

# 4" Wet-Prime Trash Pump 4HT-DDST-3-2011

## 4HT-DDST-3-2011 Dimensions

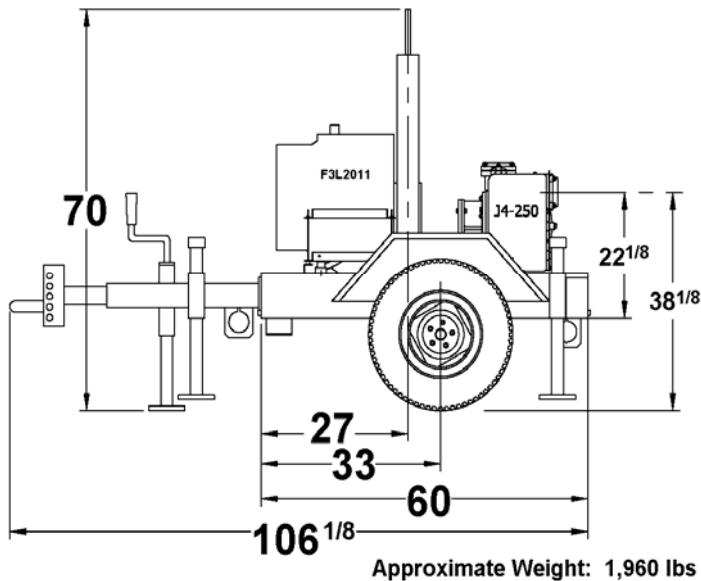

## Materials of Construction

- Pump Casing:** Heavy-duty class 30 cast-iron with built-in volute
- Impeller:** Dynamically balanced, two-vane, non-clogging, semi-open, ductile iron, with rear-equalizing vanes to reduce axial loading and prolong seal and bearing life. Diameter 9.74"
- Mechanical Seal:** Grease or oil lubricated with Tungsten Carbide rotating and stationary seal faces. All other components are 304 stainless steel and Viton.
- Head:** Rugged, back pull out design, heavy-duty class 30 cast iron with tapered bore design
- Bearings and Frame:** Heavy-duty grease lubricated bearings to carry both axial and radial loads. Heavy-duty class 30 cast iron frame.
- Shaft:** High quality carbon steel and fitted with a 304 stainless steel shaft sleeve.
- Suction Check Valve:** Built-in weighted, full-flow valve to eliminate re-priming with each cycle
- Wear Plate:** Replaceable, class 30 cast iron with abrasion resistant rubber facing to extend service life

## 4HT-DDST-3-2011 Performance Curve

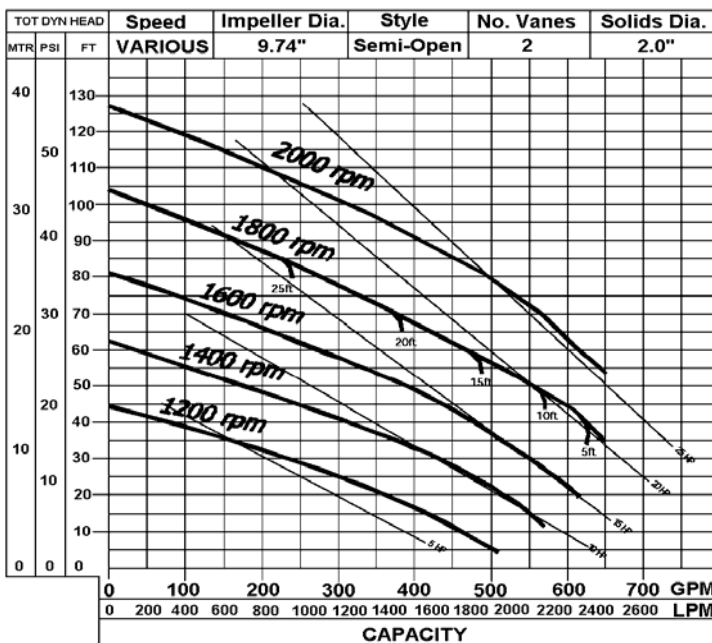

## Engine Specifications

- Engine:** Deutz F3L2011, 35 hp @ 1,800 rpm
- Type:** 3-cylinder, in-line, 4-cycle, direct-injected diesel
- Standard Equipment:** Alternator, radiator, muffler, and exhaust stack with rain protection.
- Displacement:** 142.2 cubic inches
- Fuel Economy:** .362 lb/hp-hr @ 1,800 rpm
- Safety Shutdowns:** High coolant temperature; Low oil pressure.

## Unit Specifications

- Fuel Tank Capacity:** 40 US gallons
- Fuel Consumption:** 1 gallons per hour
- Maximum Operating Speed:** 1,800 rpm
- Maximum Operating Temperature:** 212°F
- Maximum Working Pressure:** 68 psi
- Maximum Suction Lift:** 28 feet
- Maximum Casing Pressure:** 82 psi

In the interest of product improvement, Thompson Pump & Manufacturing reserves the right to change specifications without incurring any obligation for equipment previously or subsequently sold. Capacity, Head and Pump Curve are for comparative purposes. Consult engineering data for exact capabilities.  
4620 City Center Drive, Port Orange, FL, 32129, USA (800) 767-7310 \* Fax (386) 761-0362  
Email: [sales@thompsonpump.com](mailto:sales@thompsonpump.com) \* [www.thompsonpump.com](http://www.thompsonpump.com)